



Midwest Fasteners
450 Richard St.
Miamisburg, OH 45342
Website: www.midwestfasteners.com
Email: sales@midwestfasteners.com

Toll Free: (800) 852-8352
Phone: (937) 866-0463
Fax: (937) 866-4174

[All Categories](#) > [Weld Studs](#) > [Arc Weld Studs](#) > [Headed Concrete Anchor Arc Weld Studs](#)

HEADED CONCRETE ANCHOR ARC WELD STUDS

D	Min. L	HD	HT	Ferrule Code*
1/4	3/4	1/2	3/16	F250
3/8	3/4	3/4	9/32	F375
1/2	1"	1"	5/16	F500
5/8	1"	1-1/4	5/16	F625

Materials

Low Carbon Steel

AISI C1010 through C1020

Also available in stainless steel.

Mechanical Properties

Low Carbon Steel

Tensile - 60,000 psi (min.)

Elongation - 20% (in 2 inches)

Specs

ALL MIDWEST FASTENERS ARC HCA studs meet AWS specifications.

Test reports available upon request.

Ferrules

Ferrules are component parts of studs. Not sold separately.

Ferrule exterior dimensions are available upon request.

***Headed Concrete Anchors** are available for welding to flat surface, inside angles, and outside angles. Each of these applications requires the proper style stud and ferrule, so please specify your application when ordering studs.

Please click the button below to configure your Concrete Anchor Weld Studs today.

[less](#)

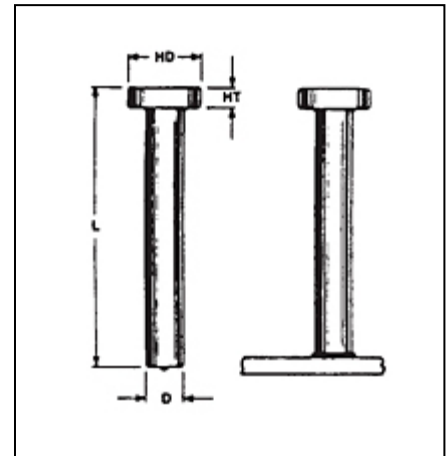

[Configure Parts](#)