



**Midwest Fasteners**  
 450 Richard St.  
 Miamisburg, OH 45342  
 Website: [www.midwestfasteners.com](http://www.midwestfasteners.com)

**Toll Free:** (800) 852-8352  
**Phone:** (937) 866-0463  
**Fax:** (937) 866-4174  
**Email:** [sales@midwestfasteners.com](mailto:sales@midwestfasteners.com)

[All Categories](#) > [Weld Studs](#) > [Arc Weld Studs](#) > [Bent No Thread Arc Weld Studs](#)

## BENT NO THREAD ARC WELD STUDS

D	Min. L	Min. X	Min. R	Ferrule Code
1/4	1-1/8	1-1/4	0.125	F250
5/16	1-1/4	1-1/2	0.218	F312
3/8	1-1/2	1-1/2	0.218	F375
7/16	1-5/8	1-5/8	0.250	F437
1/2	1-3/4	1-3/4	0.250	F500
5/8	1-7/8	2"	0.312	F625
3/4	2-3/4	3"	0.500	F750
7/8	3-1/2	3-3/8	0.500	F875

### Materials

#### Low Carbon Steel

C - 0.23% max. P - 0.04% max.  
 Mn - 0.90% max. S - 0.05% max.

#### Stainless Steel

AISI grade - 302/304/305 std.  
 Other grades available upon request.

### Mechanical Properties

#### Low Carbon Steel

Tensile - 60,000 psi (min.)  
 Yield - 50,000 psi (min.)  
 Elongation - 20% (in 2 inches)

#### Stainless Steel

Values for various grades available upon request.

### Plating

#### Low Carbon Steel

Plating is not standard.  
 Copper, nickel, and zinc available upon customer request.

#### Stainless Steel

Does not apply to Stainless.

### Ferrules

Ferrules are component parts of studs. Not sold separately.

Please click the [Request Information](#) button to configure your Bent No Thread Arc Weld Studs.

[less](#)

Arc  
Weld  
Studs

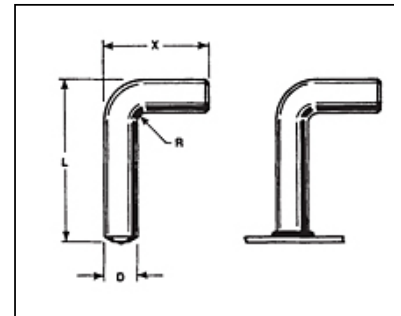

### Ferrules

Ferrules

Code	B	D	E	M	Part No.
F250	0.380	0.455	0.156	0.390	092 0005 06

F312	0.445	0.578	0.156	0.390	092 0005 07
F375	0.505	0.640	0.156	0.390	092 0005 08
F437	0.585	0.703	0.188	0.422	092 0005 09
F500	0.650	0.795	0.188	0.438	092 0005 10
F625	0.785	1.030	0.188	0.516	092 0005 11
F750	1.030	1.218	0.188	0.656	092 0005 12
F875	1.203	1.406	0.188	0.732	092 0005 13