



Midwest Fasteners
 450 Richard St.
 Miamisburg, OH 45342
 Website: www.midwestfasteners.com

Toll Free: (800) 852-8352
Phone: (937) 866-0463
Fax: (937) 866-4174
Email: sales@midwestfasteners.com

[All Categories](#) > [Weld Studs](#) > [Arc Weld Studs](#) > [Full Base Arc Weld Studs](#)

FULL BASE ARC WELD STUDS

D	Min. L	Min. BL	Max. FD	Max. FH	Ferrule Code
1/4	3/4*	0.375	0.335		F250
5/16	7/8	0.375	0.406	0.125	F312
3/8		0.500	0.468	0.141	F375
7/16	1-1/8	0.500	0.546	0.156	F437
1/2	1-1/4	0.500	0.609	0.172	F500
5/8	1-1/2	0.500	0.765	0.266	F625
3/4	1-3/4	0.675	0.906	0.335	F750
7/8	2-1/2	0.750	1.046	0.390	F875
1	2-1/2	1.000	1.203	0.468	F1000

Materials

Low Carbon Steel

C - 0.23% max. P - 0.04% max.
 Mn - 0.90% max. S - 0.05% max.

Stainless Steel

AISI grade - 302/304/305 std.
 Other grades available upon request.

Mechanical Properties

Low Carbon Steel

Tensile - 60,000 psi (min.)
 Yield - 50,000 psi (min.)
 Elongation - 20% (in 2 inches)

Stainless Steel

Values for various grades available upon request.

Plating

Low Carbon Steel

Plating is not standard.
 Copper, nickel, and zinc available upon customer request.

Stainless Steel

Does not apply to Stainless.

Ferrules

Ferrules are component parts of studs. Not sold separately.

Threads

Standard thread is UNC-2A (Rolled when possible), other threads are available upon request.
 Maximum standard thread length is 3-7/8".

Please click the [Request Information](#) button to configure your Full Base Arc Weld Studs.

[less](#)

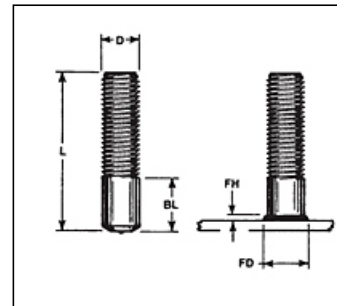

Arc
Weld
Studs

Ferrules

Ferrules

Code	B	D	E	M	Part No.
F250	0.380	0.455	0.125	0.390	092 0005 06

F312	0.445	0.578	0.156	0.390	092 0005 07
F375	0.505	0.640	0.156	0.390	092 0005 08
F437	0.585	0.703	0.188	0.422	092 0005 09
F500	0.650	0.795	0.188	0.438	092 0005 10
F625	0.785	1.030	0.188	0.516	092 0005 11
F750	1.030	1.218	0.188	0.681	092 0005 12
F875	1.203	1.406	0.194	0.734	092 0005 13
F1000	1.406	1.609	0.1250	0.843	092 0005 14