



**Midwest Fasteners**  
 450 Richard St.  
 Miamisburg, OH 45342  
 Website: [www.midwestfasteners.com](http://www.midwestfasteners.com)

**Toll Free:** (800) 852-8352  
**Phone:** (937) 866-0463  
**Fax:** (937) 866-4174  
**Email:** [sales@midwestfasteners.com](mailto:sales@midwestfasteners.com)

[All Categories](#) > [Weld Studs](#) > [Arc Weld Studs](#) > [Full Thread Arc Weld Studs](#)

## FULL THREAD ARC WELD STUDS

D	Min. L**	FD	FH	Ferrule Code
#10	3/4*	0.281	0.093	F187
1/4	3/4*	0.359	0.109	F250
5/16	3/4*	0.437	0.109	F312
3/8	3/4*	0.500	0.125	F375
7/16	7/8	0.578	0.140	F437
1/2	7/8	0.625	0.156	F500
5/8	1-1/8	0.796	0.187	F625
3/4	1-1/8	0.937	0.250	F750
7/8	1-1/2	1.093	0.312	F875

\* Ferrules used with studs 3/4" long are special "short F" ferrules.

\*\*KNOCK-OFF studs are available if shorter lengths are required.

### Materials

#### Low Carbon Steel

C - 0.23% max. P - 0.04% max.

Mn - 0.90% max. S - 0.05% max.

#### Stainless Steel

AISI grade - 302/304/305 std.

Other grades available upon request.

### Mechanical Properties

#### Low Carbon Steel

Tensile - 60,000 psi (min.)

Yield - 50,000 psi (min.)

Elongation - 20% (in 2 inches)

#### Stainless Steel

Values for various grades available upon request.

### Plating

#### Low Carbon Steel

Plating is not standard.

Copper, nickel, and zinc available upon customer request.

#### Stainless Steel

Does not apply to Stainless.

### Ferrules

Ferrules are component parts of studs. Not sold separately.

### Threads

Standard thread is UNC-2A (Rrolled when possible), other threads are available upon request.

Maximum standard thread length is 3-7/8".

### Compliances & Standards

MIL-S-24149 (Military Specification: Studs, Welding and Arc Shields (Ferrules))

Arc  
Weld  
Studs

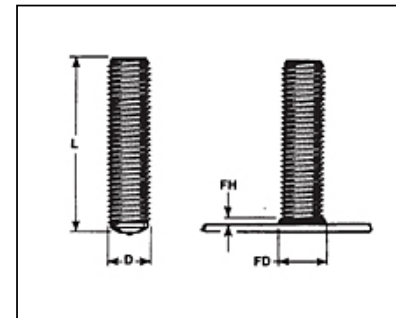

Please click the Request Information button to configure your Full Thread Arc Weld Studs.

[less](#)

Ferrules

	<b>Code</b>	<b>B</b>	<b>D</b>	<b>E</b>	<b>M</b>	<b>Part No.</b>
	F187	0.305	0.390	0.156	0.390	092 0005 05
	F250	0.380	0.455	0.156	0.390	092 0005 06
	F312	0.445	0.578	0.156	0.265	092 0005 07
Ferrules	F375	0.505	0.640	0.156	0.329	092 0005 08
	F437	0.585	0.703	0.188	0.362	092 0005 09
	F500	0.650	0.795	0.188	0.433	092 0005 10
	F625	0.785	1.030	0.188	0.526	092 0005 11
	F750	1.030	1.218	0.188	0.593	092 0005 12
	F875	1.203	1.406	0.188	0.732	092 0005 13