



Midwest Fasteners
 450 Richard St.
 Miamisburg, OH 45342
Website: www.midwestfasteners.com
Email: sales@midwestfasteners.com

Toll Free: (800) 852-8352
Phone: (937) 866-0463
Fax: (937) 866-4174

[All Categories](#) > [Weld Studs](#) > [Arc Weld Studs](#) > [Knurled Arc Weld Studs](#)

KNURLED ARC WELD STUDS

D	Min. L	GD	Ferrule Code
5/16	1"	0.327	F312

Materials

Low Carbon Steel

C - 0.23% max. P - 0.04% max.

Mn - 0.90% max. S - 0.05% max.

Mechanical Properties

Low Carbon Steel

Tensile - 60,000 psi (min.)

Elongation - 20% (in 2 inches)

Arc
Weld
Studs

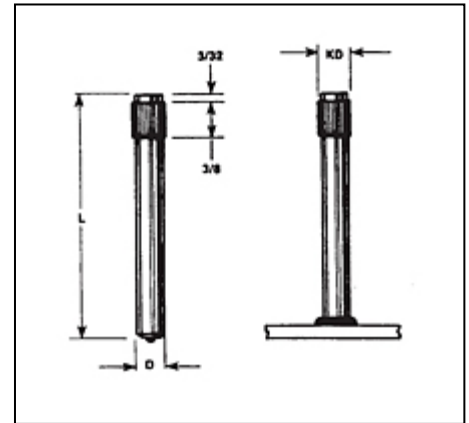

Ferrules

Ferrules are component parts of studs. Not sold separately.

Please click the [Request Information](#) button to configure your Knurled Arc Weld Studs.

Ferrules

Ferrules	Code	B	D	E	M	Part No.
	F312	0.445	0.578	0.156	0.390	092 0005 07