



Midwest Fasteners
 450 Richard St.
 Miamisburg, OH 45342
 Website: www.midwestfasteners.com

Toll Free: (800) 852-8352
Phone: (937) 866-0463
Fax: (937) 866-4174
Email: sales@midwestfasteners.com

[All Categories](#) > [Weld Studs](#) > [Arc Weld Studs](#) > [No Thread Arc Weld Studs](#)

NO THREAD ARC WELD STUDS

D	Min. L**	FD	FH	Ferrule Code
3/16	3/4*	0.281	0.093	F187
1/4	3/4*	0.359	0.109	F250
5/16	3/4*	0.437	0.109	F312
3/8	3/4*	0.500	0.125	F375
7/16	3/4*	0.578	0.140	F437
1/2	7/8	0.627	0.156	F500
5/8	1"	0.796	0.187	F625
3/4	1-1/8	0.937	0.250	F750
7/8	1-1/4	1.093	0.312	F875
1"	1-1/2	1.312	0.375	F1000

* Ferrules used with studs 3/4" long are special "short F" ferrules.

** KNOCK-OFF studs are available if shorter lengths are required.

Materials

Low Carbon Steel

C - 0.23% max. P - 0.04% max.
 Mn - 0.90% max. S - 0.05% max.

Stainless Steel

AISI grade - 302/304/305 std.
 Other grades available upon request.

Mechanical Properties

Low Carbon Steel

Tensile - 60,000 psi (min.)
 Yield - 50,000 psi (min.)
 Elongation - 20% (in 2 inches)

Stainless Steel

Values for various grades available upon request.

Plating

Low Carbon Steel

Plating is not standard.
 Copper, nickel, and zinc available upon customer request.

Stainless Steel

Does not apply to Stainless.

Ferrules

Ferrules are component parts of studs. Not sold separately.

Please click the Request Information button to configure your No Thread Arc Weld Studs.

[less](#)

Arc
Weld
Studs

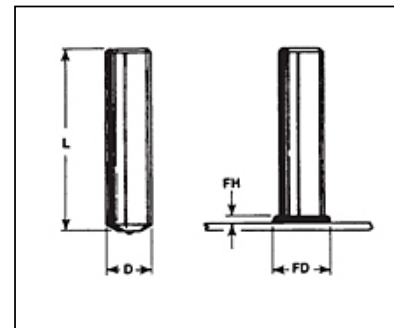

Ferrules

	Code	B	D	E	M	Part No.
	F187	0.305	0.390	0.156	0.390	092 0005 05
	F250	0.380	0.455	0.156	0.390	092 0005 06
	F312	0.445	0.578	0.156	0.265	092 0005 07
	F375	0.505	0.640	0.156	0.329	092 0005 08
Ferrules	F437	0.585	0.703	0.188	0.362	092 0005 09
	F500	0.650	0.795	0.188	0.433	092 0005 10
	F625	0.785	1.030	0.188	0.526	092 0005 11
	F750	1.030	1.218	0.188	0.593	092 0005 12
	F875	1.203	1.406	0.188	0.732	092 0005 13
	F1000	1.406	1.609	0.188	0.820	092 0005 14