



**Midwest Fasteners**  
 450 Richard St.  
 Miamisburg, OH 45342  
**Website:** [www.midwestfasteners.com](http://www.midwestfasteners.com)  
[sales@midwestfasteners.com](mailto:sales@midwestfasteners.com)

**Toll Free:** (800) 852-8352  
**Phone:** (937) 866-0463  
**Fax:** (937) 866-4174  
**Email:**

[All Categories](#) > [Insulation Fasteners](#) > [Capacitor Discharge Weld Pins & Arc Weld Pins](#) > [Double Pointed \(Arc\) Weld Pins](#)

## DOUBLE POINTED (ARC) WELD PINS

Size	D*	L	Ferrule Code
10GA	0.135	AS REQUIRED	F135

\*Other diameters available upon request.

### Materials

#### Low Carbon Steel

C - 0.23% max. P - 0.04% max.

Mn - 0.90% max. S - 0.05% max.

#### Stainless Steel

AISI grade - 302/304/305 std.

Other grades available upon request.

### Mechanical Properties

#### Low Carbon Steel

Tensile - 60,000 psi (min.)

Yield - 50,000 psi (min.)

Elongation - 20% (in 2 inches)

#### Stainless Steel

Values for various grades available upon request.

### Plating

Galvanized and Copper plating are available for Low Carbon Steel

### Annealing

Low Carbon Steel can be annealed where required.

### Washers

Self-locking washers are available in a variety of sizes, shapes, and materials.

### Application

This is the standard weld pin used when only arc stud welding equipment is available.

### Ferrules

Ferrules are component parts of studs. Not sold separately.

Please click the [Request Information](#) button to configure your [Double Pointed \(Arc\) Weld Pins](#).

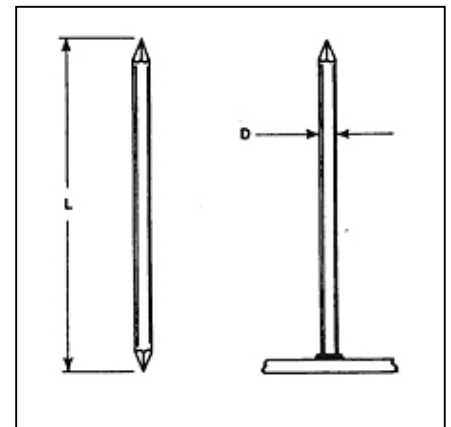

FERRULE					
Code	B	D	E	M	Part No.
F135	0.281	0.375	0.156	0.390	092 0005 04

less