



# PlenumWrap® + Plastic Pipe and Cable System

Datasheet Code US: 714-233

© 2014 Thermal Ceramics is a business of Morgan Advanced Materials



## Product Data and Installation Guide

### 1. Product Description

Building Codes require that materials exposed within plenums shall have a flame spread index of not more than 25 and a smoke developed index of not more than 50. Many plastic pipes and plastic coatings on electrical cables do not meet these requirements. Thermal Ceramics PlenumWrap+ is a thin, lightweight, and flexible wrap material tested and laboratory listed to UL 1887, NFPA 262 (UL910), and ASTM E84 to reduce flame spread and smoke development of plastic pipe and plastic insulated copper cable installed in environmental air spaces (plenums). PlenumWrap+ core blanket is manufactured using Thermal Ceramics' patented Superwool fiber, a 2192°F rated, non-combustible, alkaline-earth silicate wool with low biopersistence. PlenumWrap+ is OPL (Intertek) Listed, and is part of both OPL's and UL's Listing and Follow-up Service Programs to ensure the consistent quality essential to the critical nature of this life-safety application.

### Product Features

- Approved to reduce flame-spread (<25) and smoke development (<50) of plastic components in air plenums
- Thin and lightweight at 1/2 inch thick, 8 pcf density
- Contours easily to complex pipe and cable installations
- Fully foil encapsulated for fast and clean installation and to minimize dusting in return air plenums
- Easy to install using 1" overlaps and banding or wire ties to fasten
- Fill blanket is completely inorganic and non-combustible
- Contains 2192°F (1200°C) rated fibers for added security versus mineral wool or fiberglass fibers
- Resistant to mold growth at conditions of 75 -95 % relative humidity (ASTM D6329)
- Unaffected by oil or water
- Does not lose fire performance capabilities with age
- Available in 48 inch widths for less joints and installation labor

### 2. Applications

- PVC Pipes
- CPVC Pipes
- PP Pipes
- PVDF Pipes
- ABS Pipes
- PB Pipes
- PE Pipes
- Electrical Cables

### 3. Physical Characteristics

Duct Product	Unit	Size	Units/Ctn.	Wt./Ctn.
PlenumWrap+	Roll	1/2" x 24" x 50'	1	42 lbs.
PlenumWrap+	Roll	1/2" x 48" x 25'	2	89 lbs.
Color	White blanket with silver foil encapsulation			

### 4. Specifications/Listings

Application	Fire Resistive Rating	Enclosure System	Listing No.
Plastic Pipes	UL 1887	1 layer PlenumWrap+	OPL PP108 P UL R14229
Electric Cables	NFPA 262 (UL 910)	1 layer PlenumWrap+	OPL PP109 P UL R14229

### 5. Performance

UL 1887 NFPA 262 (UL 910)	Optical Smoke Density Peak	0.03
	Optical Smoke Density Average	0.01
	Flame Propagation (ft.)	2.6
ASTM E84	Flame Spread	15
	Smoke Developed	10

### 6. Specifications – Division 23 07 00 (or 15080)

CSI Spec and AutoCAD available online,  
[www.arcat.com/sd/clients/thermcer.html](http://www.arcat.com/sd/clients/thermcer.html)

Thermal Ceramics PlenumWrap+ is a low biopersistence fiber blanket rated to 2192F, and is listed by Intertek (OPL) as an enclosure system per ASTM E84, NFPA 252, and UL1881. Insulation is 1/2" thickness and 8# density.

Subject to Authority Having Jurisdiction approval, PlenumWrap+ shall be installed as an insulation jacketing over non-plenum rated plastic pipe and electrical jacketing (PVC and similar) to meet code requirements for maximum 25/50 rating per ASTM E84. Installation shall be performed by an experienced contractor per manufacturer instructions and applicable Intertek Listings.



## PlenumWrap®+ Plastic Pipe and Cable System

### 7. Installation (Figure 1)

The PlenumWrap+ system shall be installed by a qualified contractor in accordance with the Thermal Ceramics manufacturer's instructions.

Materials and Equipment:

- PlenumWrap+, 1/2" min. thickness, 24" wide by 50' long, and 48" wide by 25' long
- Glass filament reinforced tape (optional)
- Aluminum foil tape for sealing cut edges of foil encapsulated blanket
- Banding material, minimum 1/2" wide, 0.015" thick, carbon or stainless steel. Note: One strand of minimum 16 gauge carbon or stainless steel tie wire may be used as an alternative
- Hand tensioning tool and crimping tool

#### Installation Method:

- Cut PlenumWrap+ to a length sufficient to wrap completely around the perimeter of the pipe or cable, plus provide an overlap of not less than 1".
- Aluminum foil tape is used to seal cut edges of the encapsulated blanket during installation.
- Secure the PlenumWrap+ blanket in place by using glass filament tape as an optional temporary hold until banding or tie wire is in place.
- Cut the next adjacent wrap of PlenumWrap+ to completely wrap around the perimeter of the pipe or cable with enough excess to overlap itself not less than 1". A 1" longitudinal overlap is required onto the previous adjacent wrap.

- Banding - min. 1/2" wide, 0.015" thick carbon or stainless steel banding is placed around the entire perimeter of the insulated pipe or cable on maximum 11 1/2" centers, and 1/2" from each blanket edge. As an alternative, 16 gauge carbon or stainless steel tie wire may be used in place of banding. Tighten the banding or tie wire to hold the wrap firmly in place without cutting or damaging the wrap. Bands or tie wires may be hand tightened.

### 8. Storage:

PlenumWrap+ must be stored in a dry warehouse environment. Pallets should not be stacked.

### 9. Maintenance and Repair

No maintenance is required when installed in accordance with Thermal Ceramics installation instructions.

If damage is limited to the foil facing material, aluminum foil tape can be used to repair the foil facing.

If damage penetrates the foil facing and damages the underlying blanket, the entire section of blanket should be removed and replaced according to Thermal Ceramics installation instructions, ensuring the proper overlaps and mechanical fastening.

\*For personal protective equipment recommendations see the SDS. Thermal Ceramics and PlenumWrap+ are trademarks of Morgan Advanced Materials. PlenumWrap+ products are manufactured by Thermal Ceramics and distributed through a network of authorized distributors.

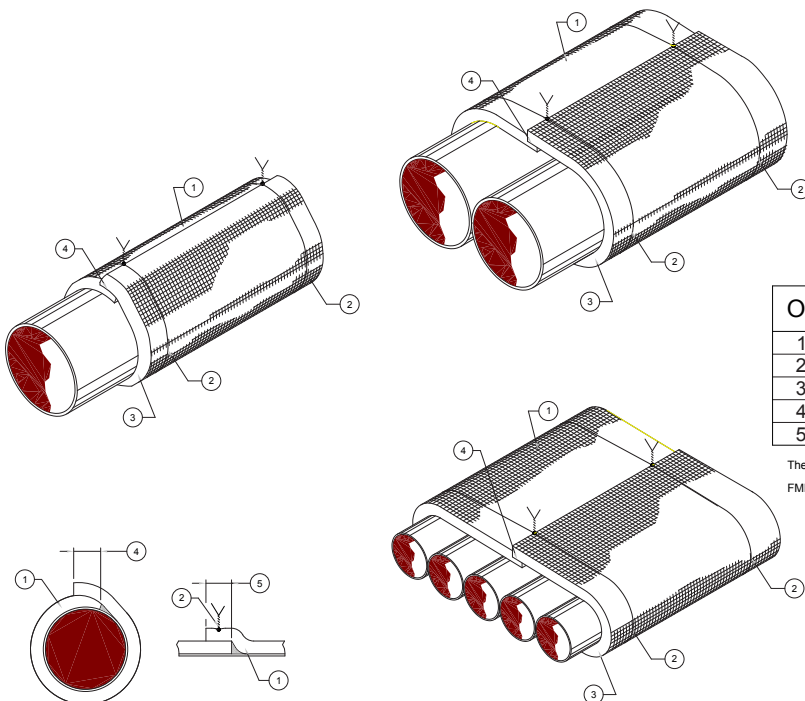

#### Omega Point Laboratories 11660-1, 11660-5

1	One layer min. 1/2" thick FireMaster Plenumwrap+
2	Tie wire or steel banding
3	Aluminum foil tape to seal cut edges
4	Perimeter overlap 1" min.
5	Longitudinal overlap 1" min.

The integrity of Firemaster duct systems is limited to the quality of the installation.

FMPW001-0